

User activities:
Army - NI
Navy - MC, OS

Review activities:
Army - AT, AV, ER, GL
Air Force - 11, 82
NSA - NS
DLA - IS

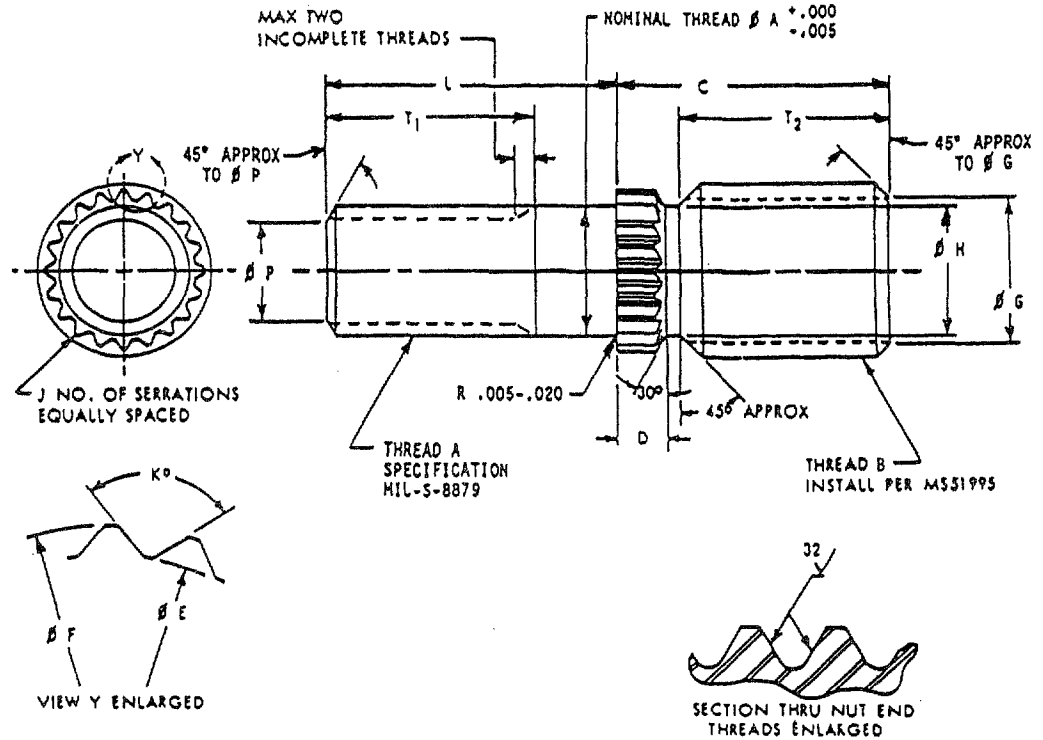

TABLE I - SHORT STUD END LENGTH (FINE THD NUT END - COARSE THD STUD END)

DASH NO.	A NUT END THREAD UNJF-3A		B STUD END THREAD (COARSE) SEE REQ 4		C	D	Ø E	Ø F	Ø G	Ø H	J	K°	T ₁	T ₂	Ø P	LOCKRING MS51990 BASIC PART NO. SEE NOTE 4
	SIZE	SIZE	PITCH DIA	MINOR DIA												
103	.1640-36	.1900-24	.1654 .1639	.1413 .1334	.380	.080	.178	.201	.122	.128	16	90°	.620	.230	.117	103P
104	.1900-32	.2500-20	.2204 .2187	.1915 .1824	.440	.080	.203	.230	.169	.177	13	102°	.620	.280	.137	104P
105	.2500-28	.3125-18	.2795 .2778	.2474 .2373	.560	.080	.255	.284	.222	.232	17	86°	.690	.390	.190	105P
106	.3125-24	.3750-16	.3378 .3358	.3017 .2906	.690	.080	.316	.345	.274	.285	20	102°	.750	.510	.242	106P
107	.3750-24	.4375-14	.3946 .3926	.3534 .3411	.750	.120	.380	.407	.322	.336	24	102°	.810	.520	.305	107P
108	.4375-20	.5000-13	.4537 .4512	.4093 .3963	.810	.120	.456	.487	.375	.391	26	102°	.880	.570	.354	108P
109	.5000-20	.5625-12	.5122 .5097	.4641 .4503	.880	.120	.567	.601	.427	.445	26	111°	1.000	.630	.416	109P

DISTRIBUTION STATEMENT A. Approved for public release; distribution is unlimited.
This military standard is approved for use by all Departments and Agencies of the Department of Defense.
Serrations for all new engineering and design applications and for repetitive use shall be made from this document when applicable.

P.A. AR	INTERNATIONAL INTEREST	TITLE	MILITARY STANDARD MS51551
Other Cust AS 99		STUD, LOCKED IN - RING LOCKED, SERRATED, UNJF THREAD NUT END, INCREASED STUD END LENGTH	
PROCUREMENT SPECIFICATION MIL-S-45909	SUPERSEDES:	PAGE 1 OF 5	

TABLE II - MEDIUM STUD END LENGTH (FINE THD NUT END - COARSE THD STUD END)

DASH NO.	A NUT END THREAD UNJF-3A		B STUD END THREAD (COARSE) SEE REQT 4		C	D	E	F	G	H	J	K ^o	T ₁	T ₂	P	LOCKRING MS51990 BASIC PART NO. SEE NOTE 4
	SIZE	SIZE	PITCH DIA	MINOR DIA												
103A	.1640-36	.1900-24	.1654 .1639	.1413 .1334	.500	.080	.178	.201	.122	.128	16	90°	.620	.360	.117	103P
104A	.1900-32	.2500-20	.2204 .2187	.1915 .1824	.560	.080	.203	.230	.169	.177	13	102°	.620	.410	.137	104P
105A	.2500-28	.3125-18	.2795 .2778	.2474 .2373	.690	.080	.255	.284	.222	.232	17	86°	.690	.510	.190	105P
106A	.3125-24	.3750-16	.3378 .3358	.3017 .2906	.880	.080	.316	.345	.274	.285	20	102°	.750	.700	.242	106P
107A	.3750-24	.4375-14	.3946 .3926	.3534 .3411	.940	.120	.380	.407	.322	.336	24	102°	.810	.710	.305	107P
108A	.4375-20	.5000-13	.4537 .4512	.4093 .3963	1.000	.120	.456	.487	.375	.391	26	102°	.880	.760	.354	108P
109A	.5000-20	.5625-12	.5122 .5097	.4641 .4503	1.060	.120	.567	.601	.427	.445	26	111°	1.000	.810	.416	109P

TABLE III - LONG STUD END LENGTH (FINE THD NUT END - COARSE THD STUD END)

DASH NO.	A NUT END THREAD UNJF-3A		B STUD END THREAD (COARSE) SEE REQT 4		C	D	E	F	G	H	J	K ^o	T ₁	T ₂	P	LOCKRING MS51990 BASIC PART NO. SEE NOTE 4
	SIZE	SIZE	PITCH DIA	MINOR DIA												
103B	.1640-36	1900-24	.1654 .1639	.1413 .1334	.620	.080	.178	.201	.122	.128	16	90°	.620	.480	.117	103P
104B	.1900-32	.2500-20	.2204 .2187	.1915 .1824	.690	.080	.203	.230	.169	.177	13	102°	.620	.540	.137	104P
105B	.2500-28	.3125-18	.2795 .2778	.2474 .2373	.810	.080	.255	.284	.222	.232	17	86°	.690	.630	.190	105P
106B	.3125-24	.3750-16	.3378 .3358	.3017 .2906	1.060	.080	.316	.345	.274	.285	20	102°	.750	.880	.242	106P
107B	.3750-24	.4375-14	.3946 .3926	.3534 .3411	1.120	.120	.380	.407	.322	.336	24	102°	.810	.890	.305	107P
108B	.4375-20	.5000-13	.4537 .4512	.4093 .3963	1.190	.120	.456	.487	.375	.391	26	102°	.880	.950	.354	108P
109B	.5000-20	.5625-12	.5122 .5097	.4641 .4503	1.310	.120	.567	.601	.427	.445	26	111°	1.000	1.060	.416	109P

APPROVED 12 MAY 87
REVISED

P.A.	AR	INTERNATIONAL INTEREST	TITLE	MILITARY STANDARD
Other Cust	AS		STUD, LOCKED IN - RING LOCKED, SERRATED, UNJF THREAD NUT END, INCREASED STUD END LENGTH	MS51551
99				
PROCUREMENT SPECIFICATION	SUPERSEDES:		PAGE	2 OF 5
MIL-S-45909				

Navy - MC, OS

Air Force - 11, 82
NSA - NS
DLA - IS

Selection for all new engineering and design applications and for repetitive use shall be made from this document when applicable.

TABLE IV - SHORT STUD END LENGTH (FINE THD NUT END - FINE THD STUD END)

DASH NO.	A NUT END THREAD UNJF-3A		B STUD END THREAD (FINE) SEE REQT 4		C	D	β E	β F	β G	β H	J	K°	T ₁	T ₂	β P	LOCKRING MS51990 BASIC PART NO. SEE NOTE 4
	SIZE	SIZE	PITCH DIA	MINOR DIA												
203	.1640-36	.1900-32	.1721 .1706	.1541 .1475	.380	.080	.178	.201	.139	.143	16	90°	.620	.250	.117	103P
204	.1900-32	.2500-28	.2296 .2281	.2090 .2014	.440	.080	.203	.230	.192	.197	13	102°	.620	.310	.137	104P
205	.2500-28	.3125-24	.2884 .2869	.2643 .2559	.560	.080	.255	.284	.245	.251	17	86°	.690	.420	.190	105P
206	.3125-24	.3750-24	.3512 .3497	.3271 .3185	.690	.080	.316	.345	.307	.306	20	102°	.750	.550	.242	106P
207	.3750-24	.4375-20	.4084 .4067	.3795 .3700	.750	.120	.380	.407	.356	.365	24	102°	.810	.550	.305	107P
208	.4375-20	.5000-20	.4711 .4694	.4422 .4325	.810	.120	.456	.487	.419	.427	26	102°	.880	.610	.354	108P
209	.5000-20	.5625-18	.5301 .5284	.4980 .4873	.880	.120	.567	.601	.472	.482	26	111°	1.000	.670	.416	109P

User activities:
Army - MI
Navy - MC, OS

Review activities:
Army - AI, AV, ER, GI
Air Force - 11, 82
NSA - NS
DLA - IS

TABLE V - MEDIUM STUD END LENGTH (FINE THD NUT END - FINE THD STUD END)

DASH NO.	A NUT END THREAD UNJF-3A		B STUD END THREAD (FINE) SEE REQT 4		C	D	β E	β F	β G	β H	J	K°	T ₁	T ₂	β P	LOCKRING MS51990 BASIC PART NO. SEE NOTE 4
	SIZE	SIZE	PITCH DIA	MINOR DIA												
203A	.1640-36	.1900-32	.1721 .1706	.1541 .1475	.500	.080	.178	.201	.139	.143	16	90°	.620	.380	.117	103P
204A	.1900-32	.2500-28	.2296 .2281	.2090 .2014	.560	.080	.203	.230	.192	.197	13	102°	.620	.430	.137	104P
205A	.2500-28	.3125-24	.2884 .2869	.2643 .2559	.690	.080	.255	.284	.245	.251	17	86°	.690	.550	.190	105P
206A	.3125-24	.3750-24	.3512 .3497	.3271 .3185	.880	.080	.316	.345	.307	.306	20	102°	.750	.740	.242	106P
207A	.3750-24	.4375-20	.4084 .4067	.3795 .3700	.940	.120	.380	.407	.356	.365	24	102°	.810	.740	.305	107P
208A	.4375-20	.5000-20	.4711 .4694	.4422 .4325	1.000	.120	.456	.487	.419	.427	26	102°	.880	.800	.354	108P
209A	.5000-20	.5625-18	.5301 .5284	.4980 .4873	1.060	.120	.567	.601	.472	.482	26	111°	1.000	.850	.416	109P

This military standard is approved for use by all Departments and Agencies of the Department of Defense. Selection for all new engineering and design applications and for repetitive use shall be made from this document when applicable.

P.A. AR	INTERNATIONAL INTEREST	TITLE	MILITARY STANDARD
Other Cust AS		STUD, LOCKED IN - RING LOCKED, SERRATED, UNJF THREAD NUT END, INCREASED STUD END LENGTH	MS51551
99			
PROCUREMENT SPECIFICATION MIL-S-45909	SUPERSEDES:	PAGE 3 OF 5	

APPROVED 12 MAY 87 REVISED

TABLE VI - LONG STUD END LENGTH (FINE THD NUT END - FINE THD STUD END)

DASH NO.	A		B		C	D	E	F	G	H	J	K°	T ₁	T ₂	P	LOCKRING MS51990 BASIC PART NO. SEE NOTE 4
	NUT END THREAD UNJF-3A		STUD END THREAD (FINE) SEE REQT 4													
	SIZE	SIZE	PITCH DIA	MINOR DIA												
203B	.1640-36	.1900-32	.1721 .1706	.1541 .1475	.620	.080	.178	.201	.139	.143	16	90°	.620	.500	.117	103P
204B	.1900-32	.2500-28	.2296 .2281	.2090 .2014	.690	.080	.203	.230	.192	.197	13	102°	.620	.560	.137	104P
205B	.2500-28	.3125-24	.2884 .2869	.2643 .2559	.810	.080	.255	.284	.245	.251	17	86°	.690	.670	.190	105P
206B	.3125-24	.3750-24	.3512 .3497	.3271 .3185	1.060	.080	.316	.345	.307	.306	20	102°	.750	.920	.242	106P
207B	.3750-24	.4375-20	.4084 .4067	.3795 .3700	1.120	.120	.380	.407	.356	.365	24	102°	.810	.920	.305	107P
208B	.4375-20	.5000-20	.4711 .4694	.4422 .4325	1.190	.120	.456	.487	.419	.427	26	102°	.880	.990	.354	108P
209B	.5000-20	.5625-18	.5301 .5284	.4980 .4873	1.310	.120	.567	.601	.472	.482	26	111°	1.000	1.100	.416	109P

REQUIREMENTS:

1. MATERIAL: CODE LETTER

- C - Steel, corrosion resistant, Type A286 (UNS S66286) conforming to AMS 5731 or AMS 5734.
- D - Steel, alloy, Grade 4130 (UNS G41300) conforming to MIL-S-6758 or Grade 8740 (UNS G87400) conforming to AMS 6322K-87.
- E - Titanium alloy, Ti-6Al-4V (UNS R56400) conforming to MIL-T-9047, Ti-6Al-4V, condition A or AMS 4967F-86.

2. PROTECTIVE COATING OR TREATMENT:

MATERIAL CODE LETTER

- C - Cleaned, descaled and passivated in accordance with ASTM A380.
- D - Cadmium plated in accordance with QQ-P-416, Type II, Class 3.
- E - Anodic treatment in accordance with AMS 2488A-83, type 2.

3. SURFACE ROUGHNESS:

Unless otherwise specified, machined surfaces shall be 125 microinches in accordance with ANSI/ASME B46.1 except for serrated collar.

4. THREADS:

The stud end thread has a special pitch diameter and minor diameter which installs into a MIL-S-8879, Class 3B tapped hole. Threads shall be in accordance with procurement specification.

5. MECHANICAL PROPERTIES:

Material code letters and corresponding tensile strengths.

Material Code Letters	Tensile Strength KSI
C	140 - 200
D	125 - 165
E	160 - 210

6. CONCENTRICITY:

Shank of nut end shall be concentric with serrated collar within .006 FIM.

7. FILLETS:

Filletts shall be .030 radius maximum.

8. EDGES:

Edges broken .003-.015 unless otherwise specified.

9. TOLERANCES:

Linear dimensions ±.005, angular dimensions ±2° unless otherwise specified.

10. PART NUMBER:

The MS part number consists of the MS number, plus the material code letter, plus the dash number, plus the second dash number for length (table VII). Table I and IV part numbers require a "-" before length dash number.

- MS51551C103-24 Stud, corrosion and heat resistant alloy, .380 stud end and 1.500 nut end lengths.
- MS51551D203A24 Stud, alloy steel, .500 stud end and 1.500 nut end lengths.
- MS51551E203B24 Stud, titanium alloy, .620 stud end and 1.500 nut end lengths.

NOTES:

1. DIMENSIONS: Dimensions in inches; to be met after plating.
2. In the event of a conflict between the text of this standard and the references cited herein, the text of this standard shall take precedence.
3. Referenced Government (or non-Government) documents of the issue listed in that issue of the Department of Defense Index of Specifications and Standards (DoDISS), specified in the solicitation form a part of this standard to the extent specified herein.
4. For applicable lockring part number coding see MS51990.

P.A.	AR	INTERNATIONAL INTEREST	TITLE	MILITARY STANDARD
Other Cust	AS		STUD, LOCKED IN - RING LOCKED, SERRATED, UNJF THREAD NUT END, INCREASED STUD END LENGTH	MS51551
99				
PROCUREMENT SPECIFICATION MIL-S-45909	SUPERSEDES:		PAGE 4 OF 5	

APPROVED 12 MAY 87

Army - MI
 Navy - MC, OS
 Army - AT, AV, ER, GL
 Air Force - 11, 82
 NSA - NS
 DLA - IS

This military standard is approved for use by all Departments and Agencies of the Department of Defense. Selection for all new engineering and design applications and for repetitive use shall be made from this document when applicable.

TABLE VII
TABULATED LENGTHS (NUT END)

L & .015 NUT END	LENGTH DASH NUMBER (TABLE APPLICABLE TO TABLES I THRU VI)						
	NUT END THD NOMINAL DIA						
	.164	.190	.250	.3125	.375	.4375	.500
.250							
.312	5						
.375	6	6	6				
.438	7	7	7				
.500	8	8	8	8			
.562	9	9	9	9	9		
.625	10	10	10	10	10	10	
.688	11	11	11	11	11	11	
.750	12	12	12	12	12	12	
.812	13	13	13	13	13	13	
.875	14	14	14	14	14	14	
.938	15	15	15	15	15	15	15
1.000	16	16	16	16	16	16	16
1.062	17	17	17	17	17	17	17
1.125	18	18	18	18	18	18	18
1.188	19	19	19	19	19	19	19
1.250	20	20	20	20	20	20	20
1.312	21	21	21	21	21	21	21
1.375	22	22	22	22	22	22	22
1.438	23	23	23	23	23	23	23
1.500	24	24	24	24	24	24	24
1.562		25	25	25	25	25	25
1.625		26	26	26	26	26	26
1.688		27	27	27	27	27	27
1.750		28	28	28	28	28	28
1.812		29	29	29	29	29	29
1.875		30	30	30	30	30	30
1.938		31	31	31	31	31	31
2.000		32	32	32	32	32	32
2.125		34	34	34	34	34	34
2.250		36	36	36	36	36	36
2.375		38	38	38	38	38	38
2.500		40	40	40	40	40	40
2.625		42	42	42	42	42	42
2.750		44	44	44	44	44	44
2.875		46	46	46	46	46	46
3.000		48	48	48	48	48	48
3.125		50	50	50	50	50	50
3.250		52	52	52	52	52	52
3.375		54	54	54	54	54	54
3.500			56	56	56		
3.625			58	58	58		
3.750			60	60	60		
3.875			62	62	62		
4.000			64	64	64		

User activities:
Army - MI
Navy - MC, OS

Review activities:
Army - AT, AV, ER, GL
Air Force - 11, B2
NSA - NS
DLA - IS

This military standard is approved for use by all Departments and Agencies of the Department of Defense. Selection for all new engineering and design applications and for repetitive use shall be made from this document when applicable.

DASH NUMBERED PARTS ABOVE THE HEAVY LINE ARE THREADED TO THE SERRATED COLLAR AS SPECIFIED HEREIN. THE MAXIMUM DISTANCE FROM THE SERRATED COLLAR TO THE FIRST FULL THREAD SHALL BE EQUAL TO THE SUM OF THE MAXIMUM FILLET RADIUS AND A MAXIMUM OF TWO INCOMPLETE THREADS. INCOMPLETE THREADS NOT TO ENTER FILLET AREA.

P.A.	AR	INTERNATIONAL INTEREST	TITLE	MILITARY STANDARD
Other Cust	AS		STUD, LOCKED IN - RING LOCKED, SERRATED, UNJF THREAD NUT END, INCREASED STUD END LENGTH	MS51551
99				
PROCUREMENT SPECIFICATION NIL-S-45909		SUPERSEDES:		PAGE 5 OF 5

APPROVED 12 MAY 87 REVISED