

MS51991D
w/Amendment 1
20 August 2015
SUPERSEDING
MS51991D
14 NOVEMBER 2012

DETAIL SPECIFICATION SHEET

INSERT, SCREW THREAD-LOCKED IN,
RING LOCKED, SERRATED

This specification is approved for use by all Departments and Agencies of the Department of Defense.

The requirements for acquiring the product described herein shall consist of this specification sheet and procurement specification MIL-DTL-45910.

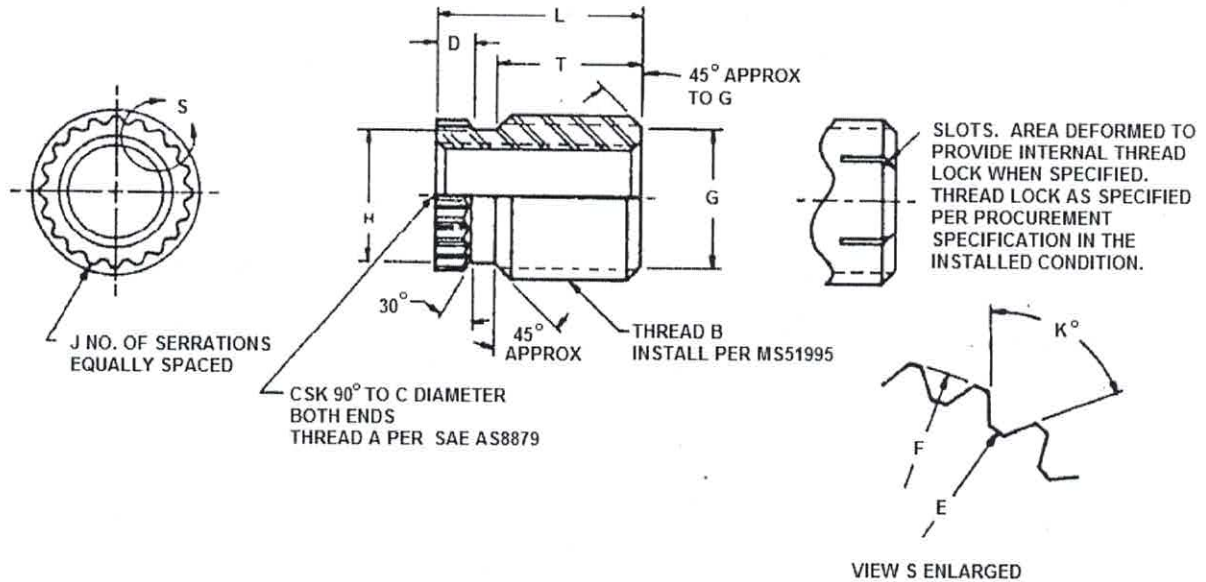

FIGURE 1. INSERT, SCREW THREAD.

MS5191D
w/Amendment 1

TABLE I. Coarse Internal and Coarse External Threads.

DASH NO.	A INTERNAL THREAD UNJC-3B		B EXTERNAL THREAD SEE THREAD NOTE			C	D ±.015	ØE + .005 -.004	ØF +.007 -.002	ØG	ØH	J	K° +2° -1°	L ±.015	T ±.015	LOCK RING PART NO. (REF) SEE NOTE 15
	SIZE	MINOR DIA (REF)	SIZE	PITCH DIA	MINOR DIA											
-102	.1120-40	.0942 .0877	.1900-24	.1648 .1633	.1407 .1334	.122 .117	.060	.152	.175	.138 .133	.148	14	102°	250	.150	MS51990-102P
-103	.1380-32	.1157 .1076	.2160-24	.1908 .1893	.1667 .1594	.149 .144	.080	.178	.201	.164 .159	.175	16	90°	310	.190	MS51990-103P
-104	.1640-32	.1417 .1336	.2500-20	2198 2178	.1909 .1824	.175 .170	.080	.203	.230	.187 .182	.197	13	102°	380	.250	MS51990-104P
-105	.1900-24	.1600 .1494	.3125-18	2789 2769	.2468 .2373	.208 .198	.090	.255	.284	.237 .237	.248	17	86°	440	.290	MS51990-105P
-106	.2500-20	.2121 .2013	.3750-16	3372 3347	.3011 .2906	.270 .260	.110	.316	.345	.291 .291	.305	20	102°	500	.330	MS51990-106P
-107	.3125-18	.2690 .2584	.5000-13	.4531 .4506	.4087 .3963	.339 .324	.120	.380	.407	.396 .396	.370	24	102°	560	.360	MS51990-107P
-108	.3750-16	.3251 .3142	.5625-12	5116 5091	.4635 .4503	.402 .387	.120	.456	.487	.425 .425	.445	26	102°	.620	.420	MS51990-108P
-109	.4375-14	.3795 .3680	.6250-11	5693 5668	.5168 .5028	.466 .451	.140	.567	.601	.503 .503	.553	26	111°	.690	.460	MS51990-109P
-110	.5000-13	.4368 .4251	.7500-10	.6885 .6860	.6308 .6156	.530 .515	.160	.687	.721	.590 .590	.612	30	111°	.750	.490	MS51990-110P

TABLE II. Fine Internal and Coarse External Threads.

DASH NO.	A INTERNAL THREAD UNJF-3B		B EXTERNAL THREAD SEE THREAD NOTE			C	D ±.015	ØE + .005 -.004	ØF +.007 -.002	ØG	ØH	J	K° +2° -1°	L ±.015	T ±.015	LOCK RING PART NO. (REF) SEE NOTE 15
	SIZE	MINOR DIA (REF)	SIZE	PITCH DIA	MINOR DIA											
-202	.1120-48	.0971 .0917	.1900-24	.1648 .1633	.1407 .1334	.122 .117	.060	.152	.175	.138 .133	.148	14	102°	250	.150	MS51990-102P
-203	.1380-40	.1202 .1137	.2160-24	.1908 .1893	.1667 .1594	.148 .143	.080	.178	.201	.164 .159	.175	16	90°	310	.190	MS51990-103P
-204	.1640-36	.1442 .1370	.2500-20	2198 2178	.1909 .1824	.175 .170	.080	.203	.230	.187 .182	.197	13	102°	380	.250	MS51990-104P
-205	.1900-32	.1675 .1596	.3125-18	2789 2769	.2468 .2373	.206 .196	.090	.255	.284	.237 .237	.248	17	86°	440	.290	MS51990-105P
-206	.2500-28	.2229 .2152	.3750-16	3372 3347	.3011 .2906	.267 .257	.110	.316	.345	.291 .291	.305	20	102°	500	.330	MS51990-106P
-207	.3125-24	.2799 .2719	.5000-13	.4531 .4506	.4087 .3963	.336 .321	.120	.380	.407	.396 .396	.370	24	102°	560	.360	MS51990-107P
-208	.3750-24	.3418 .3344	.5625-12	5116 5091	.4635 .4503	.398 .383	.120	.456	.487	.425 .425	.445	26	102°	.620	.420	MS51990-108P
-209	.4375-20	.3970 .3888	.6250-11	5693 5668	.5168 .5028	.462 .447	.140	.567	.601	.503 .503	.553	26	111°	.690	.460	MS51990-109P
-210	.5000-20	.4591 .4513	.7500-10	.6885 .6860	.6308 .6156	.525 .510	.160	.687	.721	.590 .590	.612	30	111°	.750	.490	MS51990-110P

MS51991D
w/Amendment 1

TABLE III. Fine Internal and Fine External Threads.

DASH NO.	A INTERNAL THREAD UNJF-3B		B EXTERNAL THREAD SEE THREAD NOTE			C	D	ØE	ØF	ØG	ØH	J	K°	L	T	LOCK RING PART NO. (REF) SEE NOTE 15
	SIZE	MINOR DIA (REF)	SIZE	PITCH DIA	MINOR DIA											
-311	.5625-18	5166 5084	.8750-14	.8316 .8291	.7904 .7786	589 574	.160	.783	.820	.728	.768	30	111°	.880	.620	MS51990-111P
(a) -312	.6250-18	5788 5709	1.0000-14	.9566 .9541	.9154 .9036	.685 .675	.160	.894	.932	.850	.882	38	102°	1.000	.740	MS51990-112P
-312.1	.6250-18	5788 5709	1.0000-12	.9491 .9466	.9010 .8878	.685 .675	.160	.894	.932	.850	.882	38	102°	1.000	.740	MS51990-112P
-313	.7500-16	6977 6892	1.1250-12	1.0741 1.0716	1.0260 1.0128	.777 .762	.160	1.029	1.074	.950	1.002	36	111°	1.120	.800	MS51990-113P
-314	.8750-14	8152 8055	1.2500-12	1.1991 1.1966	1.1510 1.1378	.904 .889	.190	1.169	1.214	1.127	1.127	48	90°	1.250	.900	MS51990-114P
-315	1.0000-12	9298 9189	1.3750-12	1.3241 1.3216	1.2760 1.2628	1.029 1.014	.190	1.273	1.318	1.202	1.252	42	111°	1.380	1.020	MS51990-115P

(a) Inactive (not to be used for new design)

TABLE IV. Interchangeability – see note 14

Part Numbers					
Cancelled (CRES 17-10P)	New (CRES A-286)	Cancelled (CRES 17-10P)	New (CRES A-286)	Cancelled (CRES 17-10P)	New (CRES A-286)
MS51991	MS51991	MS51991	MS51991	MS51991	MS51991
C102	E102	C202	E202	C311	E311
C103	E103	C203	E203	C312	E312
C104	E104	C204	E204	C312.1	E312.1
C105	E105	C205	E205	C313	E313
C106	E106	C206	E206	C314	E314
C107	E107	C207	E207	C315	E315
C108	E108	C208	E208		
C109	E109	C209	E209		
C110	E110	C210	E210		

NOTES:

- Material:** Steel, carbon, composition C117 in accordance with ASTM A108.
Steel, corrosion-resistant, Type A286 (UNS S66286) per SAE AMS5731, SAE AMS5732, SAE AMS5734 or SAE AMS5737.
- Protective coating:** Steel, carbon shall be cadmium plated in accordance with SAE AMS-QQ-P-416, Type II, Class 3.
Steel, corrosion-resistant, shall be passivated in accordance with SAE AMS2700.
Steel, corrosion-resistant, with internal thread lock for aerospace applications shall also be solid film lubricant coated per SAE AS5272 Type I¹.
Steel, corrosion-resistant, with internal thread lock for non-aerospace applications shall also be solid film lubricant coated per MIL-PRF-46010².
- Surface roughness:** Machine surfaces shall be 125 microinches in accordance with ASME B46.1 except serrated collar.
- Threads:** The external thread has a special pitch diameter and minor diameter which installs into a national class 3 tapped hole. Threads also shall be in accordance with procurement specification.

¹SAE AS5272 Type 1 lubricant is technically equivalent to MIL-L-46010 Type I lubricant which superseded MIL-L-8937 lubricant used in previous revisions.

²MIL-PRF-46010 lubricant is lead (Pb) free and is not technically equivalent to MIL-L-46010 Type I lubricant which superseded MIL-L-8937 lubricant used in previous revisions. Use of MIL-PRF-46010 in aerospace applications must first be validated.

MS51991D
w/Amendment 1

5. Heat treatment: Inserts shall be capable of developing 125,000 PSI tensile strength as specified in the procurement specification.
6. Hardness: Steel, carbon, Rockwell B 78 minimum.
Steel, corrosion-resistant, Rockwell B 83.
7. Fillets: .015 R max.
8. Edges: Break sharp edges .003 - .015 unless otherwise specified.
9. Dimensions: Dimensions are in inches and are met after plating.
10. Tolerances: Linear dimensions \pm .005, angular dimensions \pm 2°.
11. Part numbers: The MS part number shall consist of the basic MS number plus the dash number. Add "E" in lieu of "DASH" for corrosion resistant steel. Add "L" as suffix to dash number for internal thread lock for aerospace applications (See Note 2). Add "LM" as suffix to dash number for internal thread lock for non-aerospace applications (See Note 2).

Examples: MS51991-205 Insert, carbon steel, non-locking.
 MS51991E205 Insert, CRES, non-locking.
 MS51991-205L Insert, carbon steel, internal thread lock, aerospace applications.
 MS51991E205L Insert, CRES, internal thread lock, aerospace applications.
 MS51991E205LM Insert, CRES, internal thread lock, non-aerospace applications.
12. For design feature purposes, this standard takes precedence over procurement documents referenced herein.
13. Referenced documents shall be of the same issue in effect on date of invitation for bid.
14. The dash numbers C100, C200, and C300" series CRES inserts in the original issue of this standard are cancelled/inactivated after approval date of revision "A" indicated on this document. The cancelled inserts should be used on existing callouts until stock is depleted. Use the new "E100, E200, and E300" series CRES inserts for replacement of "C100, C200, and C300"series CRES inserts in accordance with Table IV.
15. For applicable locking dash number coding see SAE AS51990.
16. Amendment notations. The margins of this specification are marked with vertical lines to indicate modifications generated by this amendment. This was done as a convenience only and the Government assumes no liability whatsoever for any inaccuracies in these notations. Bidders and contractors are cautioned to evaluate the requirements of this document based on the entire content irrespective of the marginal notations.

MILITARY INTEREST

Custodians:

Army - AR
Navy - AS
Air Force - 99

Preparing activity:

DLA - IS

(Project 5325-2015-009)

Review activities:

Army – AT, AV, MI
Navy – OS
Air Force – 71

NOTE: The activities listed above were interested in this document as of the date of this document. Since organizations and responsibilities can change, you should verify the currency of the information above using the ASSIST Online database at <https://assist.dla.mil>.